



# PanBlast™ Corsa II BSP Abrasive Control Valve - Urethane Sleeve Type



Surface Finishing  
Equipment Group

Distributed by: Hogg Blasting & Finishing Equipment Ltd. Tel: 0191 415 3030 - Abraclean Ltd. Tel: 0161 480 8087 - Part of the Surface Finishing Equipment Group - www.sieg.co.uk

## PanBlast™ Corsa II BSP Abrasive Control Valve

The PanBlast™ Corsa II BSP Abrasive Control Valve has been developed from the Series I valve, to provide even greater reliability and efficiency.

### PanBlast™ Corsa II BSP Valve Design Features:

- Increased spring force for quicker valve actuation, which improves sleeve and seat service life.
- Improved plunger seal arrangement to ensure precise sealing and extended seal service life.
- Breather hole re-located and exhaust filter added to prevent dust from entering air chamber.
- Hexagon cast into valve top for easier assembly and disassembly.
- Connecting nipple carburise hardened to 55HRC, which greatly reduced wear.
- Piston travel stop nut added.
- Plunger seat design improved to provide better sealing and operating life.
- Improved piston design for smoother operation and better reliability.
- Available in both NPT & BSP threaded versions, with either 1¼" or 1½" threads.
- Plunger, seat holder, bush and plunger cap now feature stainless steel construction.
- Clean out/drain port for improved servicing and maintenance.
- Graduation markings on the valve top for more precise metering and abrasive control.



The PanBlast™ Series II Corsa BSP Valve is a normally closed abrasive metering valve requiring a pilot compressed air signal to open it, which then permits abrasive flow. The Series II Corsa BSP Valve may be used on both pressure hold and pressure release blast pots.

When used on pressure hold, multiple outlet pots, the Corsa II BSP Valve permits each operator to blast totally independent of each other. When used with pressure release blast pots, the Corsa II BSP Valve prevents the blast hose filling with abrasive each time the pot is depressurized.



Blast Pots & Cabinets - Remote Control Valves - Abrasive Control Valves - Blast Nozzles - Nozzle Holders & Couplings - Helmets & Breathing Air Filters

Distributed by: Hogg Blasting & Finishing Equipment Ltd. Tel: 0191 415 3030 - Abraclean Ltd. Tel: 0161 480 8087 - Part of the Surface Finishing Equipment Group - www.sfeq.co.uk

## PanBlast™ Corsa II BSP Valve Assemblies -

Stock Code	Description	Weight
BAC-VA-PB-0117	Corsa II BSP Valve complete with 1 1/4" M x 1 1/4" M Pipe Nipple (Item 21)	5.90kg (12.98lbs)
BAC-VA-PB-0118	Corsa II BSP Valve complete with 1 1/2" M x 1 1/2" M Pipe Nipple (Item 22)	6.10kg (13.42lbs)

## PanBlast™ Corsa II BSP Valve Parts List -

Item	Stock Code	Description	Qty
1	BAC-VA-PB-0093	Top	1
2	YAC-VA-PB-0095	Anti-Vibration Washer	1
3	YAC-VA-PB-0094	Stop Ring	1
4	YAC-VA-PB-0096	Spring	1
5	YAC-VA-PB-0097	Piston Seal	1
6	YAC-VA-PB-0124	Plunger Cover	1
7	YAC-VA-PB-0137	Nylon Washer	1
8	YAC-VA-PB-0098	Piston	1
9	BAC-VA-PB-0099	Tungsten Plunger	1
10	BAC-VA-PB-0100	Cylinder	1
11	YAC-VA-PB-0052	Plunger Seal	4
12	YAC-BS-PB-0032	O-Ring	2
13	YAC-VA-PB-0125	Bush	1
14	YAC-VA-PB-0120	Urethane Sleeve	1
15	YAC-VA-PB-0194	Base	1
16	YAC-FN-PB-0258	Flat Washer	4
17	YAC-FN-PB-0104	Hex Head Bolt	4
18	BAC-AF-PB-0163	Exhaust Filter	1
19	YAC-PF-PB-0231	Square Head Plug	1
20	BAC-VA-PB-0092	Control Knob	1
21	BAC-VA-PB-0090	1 1/4" x 1 1/4" Pipe Nipple (Use with BAC-VA-PB-0117)	1
22	BAC-VA-PB-0091	1 1/2" x 1 1/2" Pipe Nipple (Use with BAC-VA-PB-0118)	1

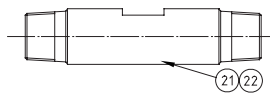
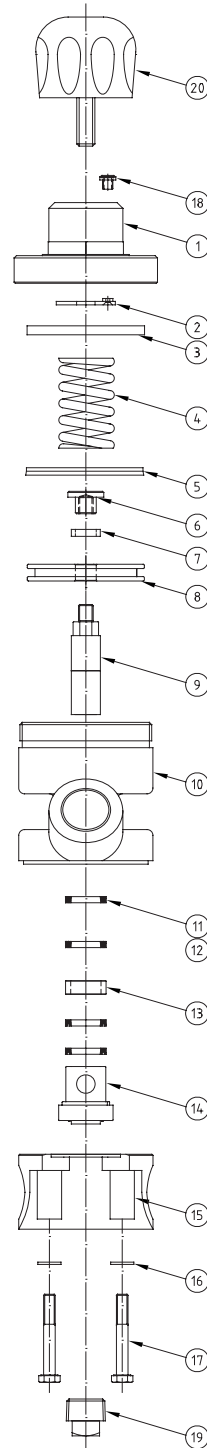

## PanBlast™ Corsa II BSP Valve Service Kits -

Stock Code	Description
BAC-VA-PB-0119	Corsa II BSP Valve Urethane Seal Kit - Includes items 5, 11, 12, 13 & 14
BAC-VA-PB-0139	Corsa II BSP Valve Piston Kit - Includes items 2, 3, 4, 5, 6, 7 & 8
BAC-VA-PB-0140	Corsa II BSP Valve Base Kit - Includes items 15, 16 & 17

The Corsa II BSP Valve may also be fitted with an abrasive cut off switch to stop abrasive flow, but still permit air flow to the blast nozzle, to create a blow down function. A plunger and orifice sleeve assembly meters the abrasive flow to the blast nozzle. Abrasive flow adjustment is via a metering knob that adjusts the depth of the plunger travel within the orifice sleeve. The standard sleeve is manufactured from wear resistant urethane, and an optional tungsten carbide sleeve and seat arrangement is also available for applications involving high wear rates.

Blast Pots & Cabinets - Remote Control Valves - Abrasive Control Valves - Blast Nozzles - Nozzle Holders & Couplings - Helmets & Breathing Air Filters - Blast Suits



Surface Finishing  
Equipment Group



PanBlast™  
www.panblast.com

Distributed by:  
Hogg Blasting & Finishing Equipment Ltd  
Tel: 0191 415 3030

Abraclean Ltd  
Tel: 0161 480 8087

Part of the Surface Finishing Equipment Group  
www.sfeq.co.uk



# PanBlast™ Corsa II BSP Abrasive Control Valve - Tungsten Sleeve Type



Surface Finishing  
Equipment Group

Distributed by: Hogg Blasting & Finishing Equipment Ltd Tel: 0191 415 3030 - Abraclean Ltd Tel: 0161 480 8087 - Part of the Surface Finishing Equipment Group - www.sieg.co.uk

## **PanBlast™ Corsa II BSP Abrasive Control Valve**

The PanBlast™ Corsa II BSP Abrasive Control Valve has been developed from the Series I valve, to provide even greater reliability and efficiency.



### **PanBlast™ Corsa II BSP Valve Design Features:**

- Increased spring force for quicker valve actuation, which improves sleeve and seat service life.
- Improved plunger seal arrangement to ensure precise sealing and extended seal service life.
- Breather hole re-located and exhaust filter added to prevent dust from entering air chamber.
- Hexagon cast into valve top for easier assembly and disassembly.
- Connecting nipple carburise hardened to 55HRC, which greatly reduced wear.
- Piston travel stop nut added.
- Plunger seat design improved to provide better sealing and operating life.
- Improved piston design for smoother operation and better reliability.
- Available in both NPT & BSP threaded versions, with either 1¼" or 1½" threads.
- Plunger, seat holder, bush and plunger cap now feature stainless steel construction.
- Clean out/drain port for improved servicing and maintenance.
- Graduation markings on the valve top for more precise metering and abrasive control.

The PanBlast™ Series II Corsa BSP Valve is a normally closed abrasive metering valve requiring a pilot compressed air signal to open it, which then permits abrasive flow. The Series II Corsa Valve may be used on both pressure hold and pressure release blast pots.

When used on pressure hold, multiple outlet pots, the Corsa II BSP Valve permits each operator to blast totally independent of each other. When used with pressure release blast pots, the Corsa II BSP Valve prevents the blast hose filling with abrasive each time the pot is depressurized.



Blast Pots & Cabinets - Remote Control Valves - Abrasive Control Valves - Blast Nozzles - Nozzle Holders & Couplings - Helmets & Breathing Air Filters

Distributed by: Hogg Blasting & Finishing Equipment Ltd. Tel: 0191 415 3030 - Abraclean Ltd. Tel: 0161 480 8087 - Part of the Surface Finishing Equipment Group - www.sfeg.co.uk

## PanBlast™ Corsa II BSP Valve Assemblies -

Stock Code	Description	Weight
BAC-VA-PB-0089	Corsa II BSP Valve complete with 1 1/4" M x 1 1/4" M Pipe Nipple (Item 24)	6.20kg (13.64lbs)
BAC-VA-PB-0114	Corsa II BSP Valve complete with 1 1/2" M x 1 1/2" M Pipe Nipple (Item 25)	6.40kg (14.08lbs)

## PanBlast™ Corsa II BSP Valve Parts List -

Item	Stock Code	Description	Qty
1	BAC-VA-PB-0093	Top	1
2	YAC-VA-PB-0095	Anti-Vibration Washer	1
3	YAC-VA-PB-0094	Stop Ring	1
4	YAC-VA-PB-0096	Spring	1
5	YAC-VA-PB-0097	Piston Seal	1
6	YAC-VA-PB-0124	Plunger Cover	1
7	YAC-VA-PB-0137	Nylon Washer	1
8	YAC-VA-PB-0098	Piston	1
9	BAC-VA-PB-0099	Tungsten Plunger	1
10	BAC-VA-PB-0100	Cylinder	1
11	YAC-VA-PB-0052	Plunger Seal	4
12	YAC-BS-PB-0032	O-Ring	2
13	YAC-VA-PB-0125	Bush	1
14	BAC-VA-PB-0102	Tungsten Carbide Sleeve	1
15	YAC-VA-PB-0103	Urethane Seat	1
16	YAC-VA-PB-0213	Seat Holder	1
17	YAC-BS-PB-0034	O-Ring	1
18	YAC-VA-PB-0194	Base	1
19	YAC-FN-PB-0258	Flat Washer	4
20	YAC-FN-PB-0104	Hex Head Bolt	4
21	BAC-AF-PB-0163	Exhaust Filter	1
22	YAC-PF-PB-0231	Square Head Plug	1
23	BAC-VA-PB-0092	Control Knob	1
24	BAC-VA-PB-0090	1 1/4" x 1 1/4" Pipe Nipple (Use with BAC-VA-PB-0089)	1
25	BAC-VA-PB-0091	1 1/2" x 1 1/2" Pipe Nipple (Use with BAC-VA-PB-0114)	1

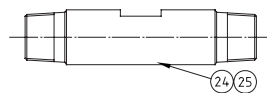

## PanBlast™ Corsa II BSP Valve Service Kits -

Stock Code	Description
BAC-VA-PB-0138	Corsa II BSP Valve Tungsten Seat Kit - Includes items 15, 16 & 17
BAC-VA-PB-0113	Corsa II BSP Tungsten Seal Kit - Includes items 5, 11, 12, 13, 14, 15, 16 & 17
BAC-VA-PB-0139	Corsa II BSP Valve Piston Kit - Includes items 2, 3, 4, 5, 6, 7 & 8
BAC-VA-PB-0140	Corsa II BSP Valve Base Kit - Includes items 18, 19 & 20

The Corsa II BSP Valve may also be fitted with an abrasive cut off switch to stop abrasive flow, but still permit air flow to the blast nozzle, to create a blow down function. A plunger and orifice sleeve assembly meters the abrasive flow to the blast nozzle. Abrasive flow adjustment is via a metering knob that adjusts the depth of the plunger travel within the orifice sleeve. The standard sleeve is manufactured from wear resistant urethane, and an optional tungsten carbide sleeve and seat arrangement is also available for applications involving high wear rates.

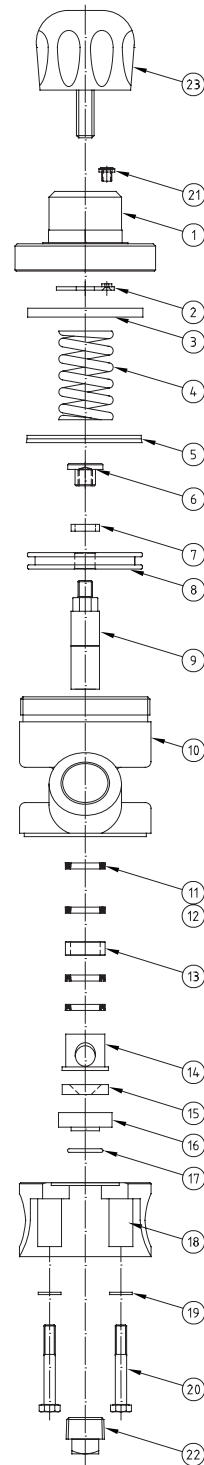

Blast Pots & Cabinets - Remote Control Valves - Abrasive Control Valves - Blast Nozzles - Nozzle Holders & Couplings - Helmets & Breathing Air Filters - Blast Suits



Surface Finishing  
Equipment Group



PanBlast™  
www.panblast.com

Distributed by:  
Hogg Blasting & Finishing Equipment Ltd  
Tel: 0191 415 3030

Abraclean Ltd  
Tel: 0161 480 8087

Part of the Surface Finishing Equipment Group  
www.sfeg.co.uk



# PanBlast™ Corsa NPT Abrasive Control Valve - Urethane Sleeve Type



Surface Finishing  
Equipment Group

Distributed by: Hogg Blasting & Finishing Equipment Ltd. Tel: 0191 415 3030 - Abraclean Ltd. Tel: 0161 480 8087 - Part of the Surface Finishing Equipment Group - www.sfeq.co.uk

## PanBlast™ Corsa NPT Abrasive Control Valve

The PanBlast™ Corsa NPT Abrasive Control Valve is a well-established first generation “industry standard” automatic on/off plunger type valve.



### PanBlast™ Corsa NPT Valve Design Features:

- Increased spring force for quicker valve actuation, which improves sleeve and seat service life.
- Lip plunger seal arrangement to ensure precise sealing and extended seal service life.
- Breather hole re-located and exhaust filter added to prevent dust from entering air chamber.
- Hexagon cast into valve top for easier assembly and disassembly.
- Connecting nipple carburise hardened to 55HRC, which greatly reduces wear.
- Improved plunger and urethane sleeve providing greater reliability.
- Plunger seat design improved to provide better sealing and operating life.
- Improved piston design for smoother operation and better reliability.
- Available in North American NPT thread version, with either 1¼" or 1½" threads.

The PanBlast™ Corsa NPT Valve is a normally closed abrasive metering valve requiring a pilot compressed air signal to open it, which then permits abrasive flow. The Corsa NPT Valve may be used on both pressure hold and pressure release blast pots.

When used on pressure hold, multiple outlet pots, the Corsa NPT Valve permits each operator to blast totally independent of each other. When used with pressure release blast pots, the Corsa NPT Valve prevents the blast hose filling with abrasive each time the pot is depressurized.



Blast Pots & Cabinets - Remote Control Valves - Abrasive Control Valves - Blast Nozzles - Nozzle Holders & Couplings - Helmets & Breathing Air Filters

All data and information is subject to change without notice. Brochure reference # 04-011

Distributed by: Hogg Blasting & Finishing Equipment Ltd. Tel: 0191 415 3030 - Abraclean Ltd. Tel: 0161 480 8087 - Part of the Surface Finishing Equipment Group - www.sfeg.co.uk

## PanBlast™ Corsa NPT Valve Assemblies -

Stock Code	Description	Weight
BAC-VA-PB-0164	Corsa NPT Valve complete with 1 1/4" M x 1 1/4" M Pipe Nipple (Item 19)	5.95kg (13.09lbs)
BAC-VA-PB-0162	Corsa NPT Valve complete with 1 1/2" M x 1 1/2" M Pipe Nipple (Item 20)	5.82kg (12.80lbs)

## PanBlast™ Corsa NPT Valve Parts List -

Item	Stock Code	Description	Qty
1	BAC-VA-PB-0154	Top	1
2	YAC-VA-PB-0095	Anti-Vibration Washer	1
3	YAC-VA-PB-0094	Stop Ring	1
4	YAC-VA-PB-0096	Spring	1
5	YAC-VA-PB-0097	Piston Seal	1
6	YAC-FN-0298-00	Nut 1/2" UNC (ZP)	1
7	YAC-VA-PB-0155	Piston	1
8	BAC-VA-PB-0219	Tungsten Carbide Plunger	1
9	BAC-VA-PB-0157	Cylinder	1
10	YAC-VA-PB-0052	Plunger Seal	1
11	YAC-BS-PB-0032	O-Ring	1
12	YAC-VA-PB-0120	Urethane Sleeve	1
13	YAC-VA-PB-0160	Base	1
14	YAC-FN-PB-0258	Flat Washer 3/8" (ZP)	4
15	YAC-FN-PB-0104	Hex Head Bolt	4
16	BAC-AF-PB-0163	Exhaust Filter	1
17	YAC-PF-PB-0234	Elbow c/w Nut	1
18	BAC-VA-PB-0168	Control Knob	1
19	BAC-VA-PB-0128	1 1/4" x 1 1/4" Pipe Nipple (Use with BAC-VA-PB-0164)	1
20	BAC-VA-PB-0129	1 1/2" x 1 1/2" Pipe Nipple (Use with BAC-VA-PB-0162)	1

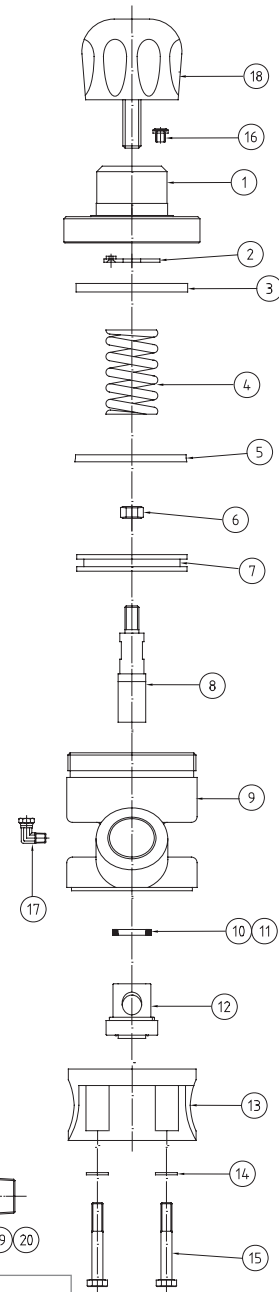

## PanBlast™ Corsa NPT Valve Service Kits -

Stock Code	Description
BAC-VA-PB-0166	Corsa NPT Valve Urethane Service Kit - Includes items 5, 8, 10, 11, 12
BAC-VA-PB-0189	Corsa NPT Valve Lower Seal Kit - Includes items 5, 10, 11 & 12
BAC-VA-PB-0211	Corsa NPT Valve Base Kit - Includes items 13, 14 & 15
BAC-VA-PB-0029	Corsa NPT Valve Piston Kit - Includes items 2, 3, 4, 5, 6 & 7

The Corsa NPT Valve may also be fitted with an abrasive cut off switch to stop abrasive flow, but still permit air flow to the blast nozzle, to create a blow down function. A plunger and orifice sleeve assembly meters the abrasive flow to the blast nozzle. Abrasive flow adjustment is via a metering knob that adjusts the depth of the plunger travel within the orifice sleeve. The standard sleeve is manufactured from wear resistant urethane, and an optional tungsten carbide sleeve and seat arrangement is also available for applications involving high wear rates.

Blast Pots & Cabinets - Remote Control Valves - Abrasive Control Valves - Blast Nozzles - Nozzle Holders & Couplings - Helmets & Breathing Air Filters - Blast Suits



Surface Finishing  
Equipment Group



PanBlast™  
www.panblast.com

Distributed by:  
Hogg Blasting & Finishing Equipment Ltd  
Tel: 0191 415 3030

Abraclean Ltd  
Tel: 0161 480 8087

Part of the Surface Finishing Equipment Group  
www.sfeg.co.uk



# PanBlast™ Corsa NPT Abrasive Control Valve - Tungsten Sleeve Type



Surface Finishing  
Equipment Group

## PanBlast™ Corsa NPT Abrasive Control Valve

The PanBlast™ Corsa NPT Abrasive Control Valve is a well-established first generation “industry standard” automatic on/off plunger type valve.



### PanBlast™ Corsa NPT Valve Design Features:

- Increased spring force for quicker valve actuation, which improves sleeve and seat service life.
- Lip plunger seal arrangement to ensure precise sealing and extended seal service life.
- Breather hole re-located and exhaust filter added to prevent dust from entering air chamber.
- Hexagon cast into valve top for easier assembly and disassembly.
- Connecting nipple carburise hardened to 55HRC, which greatly reduces wear.
- Improved carbide plunger sleeve using mechanical fixturing for greater reliability and extended service life of the feed orifice.
- Plunger seat design improved to provide better sealing and operating life.
- Improved piston design for smoother operation and better reliability.
- Available in North American NPT thread version, with either 1¼" or 1½" threads.

The PanBlast™ Corsa NPT Valve is a normally closed abrasive metering valve requiring a pilot compressed air signal to open it, which then permits abrasive flow. The Corsa NPT Valve may be used on both pressure hold and pressure release blast pots.

When used on pressure hold, multiple outlet pots, the Corsa NPT Valve permits each operator to blast totally independent of each other. When used with pressure release blast pots, the Corsa NPT Valve prevents the blast hose filling with abrasive each time the pot is depressurized.

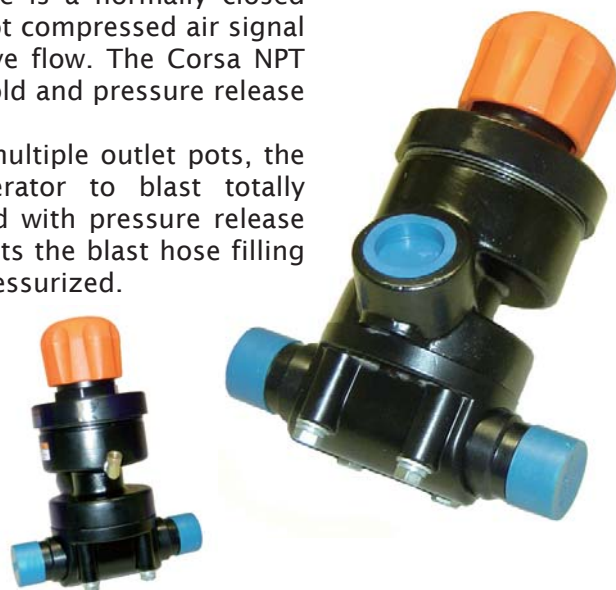

## PanBlast™ Corsa NPT Valve Assemblies -

Stock Code	Description	Weight
BAC-VA-PB-0165	Corsa NPT Valve complete with 1 1/4" M x 1 1/4" M Pipe Nipple (Item 22)	6.13kg (13.49lbs)
BAC-VA-PB-0163	Corsa NPT Valve complete with 1 1/2" M x 1 1/2" M Pipe Nipple (Item 23)	6.08kg (13.38lbs)

## PanBlast™ Corsa NPT Valve Parts List -

Item	Stock Code	Description	Qty
1	BAC-VA-PB-0154	Top	1
2	YAC-VA-PB-0095	Anti-Vibration Washer	1
3	YAC-VA-PB-0094	Stop Ring	1
4	YAC-VA-PB-0096	Spring	1
5	YAC-VA-PB-0097	Piston Seal	1
6	YAC-FN-0298-00	Nut 1/2" UNC (ZP)	1
7	YAC-VA-PB-0155	Piston	1
8	BAC-VA-PB-0219	Tungsten Carbide Plunger	1
9	BAC-VA-PB-0157	NPT Valve - Cylinder	1
10	YAC-VA-PB-0052	Plunger Seal	1
11	YAC-BS-PB-0032	O-Ring	1
12	BAC-VA-PB-0102	Tungsten Carbide Sleeve	1
13	YAC-VA-PB-0103	Urethane Seat	1
14	YAC-VA-PB-0104	Seat Holder	1
15	YAC-BS-PB-0034	O-Ring	1
16	YAC-VA-PB-0160	Base	1
17	YAC-FN-PB-0258	Flat Washer	4
18	YAC-FN-PB-0104	Hex Head Bolt	4
19	BAC-AF-PB-0163	Exhaust Filter	1
20	YAC-PF-PB-0234	Elbow c/w Nut	1
21	BAC-VA-PB-0168	Control Knob	1
22	BAC-VA-PB-0128	1 1/4" x 1 1/4" Pipe Nipple (Use with BAC-VA-PB-0165)	1
23	BAC-VA-PB-0129	1 1/2" x 1 1/2" Pipe Nipple (Use with BAC-VA-PB-0163)	1

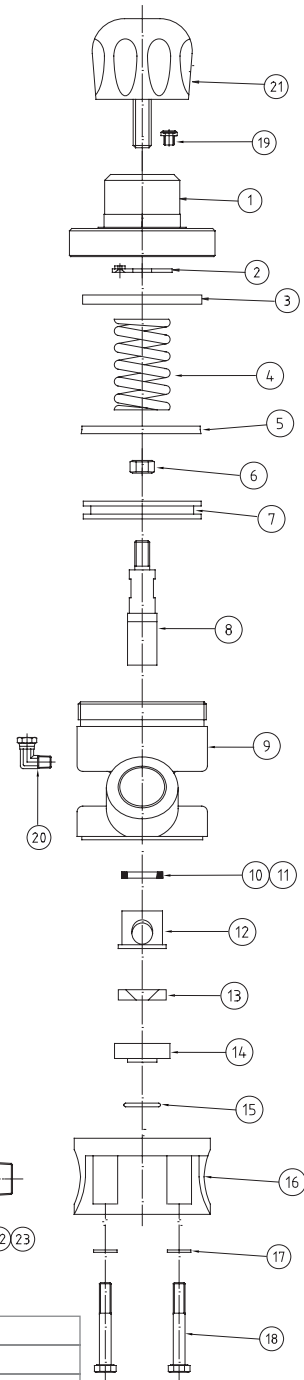

## PanBlast™ Corsa NPT Valve Service Kits -

Stock Code	Description
BAC-VA-PB-0028	Corsa NPT Valve Tungsten Seat Kit - Includes items 13, 14 & 15
BAC-VA-PB-0188	Corsa NPT Valve Upper Seal Kit - Includes items 5, 10, 11, 13 & 15
BAC-VA-PB-0029	Corsa NPT Valve Piston Kit - Includes items 2, 3, 4, 5, 6 & 7
BAC-VA-PB-0211	Corsa NPT Valve Base Kit - Includes items 16, 17 & 18
BAC-VA-PB-0167	Corsa NPT Valve Service Kit - Includes items 5, 8, 10, 11, 12, 13, 14 & 15

The Corsa NPT Valve may also be fitted with an abrasive cut off switch to stop abrasive flow, but still permit air flow to the blast nozzle, to create a blow down function. A plunger and orifice sleeve assembly meters the abrasive flow to the blast nozzle. Abrasive flow adjustment is via a metering knob that adjusts the depth of the plunger travel within the orifice sleeve. The standard sleeve is manufactured from wear resistant urethane, and an optional tungsten carbide sleeve and seat arrangement is also available for applications involving high wear rates.



Surface Finishing  
Equipment Group



PanBlast™  
www.panblast.com

Distributed by:  
Hogg Blasting & Finishing Equipment Ltd  
Tel: 0191 415 3030

Abraclean Ltd  
Tel: 0161 480 8087

Part of the Surface Finishing Equipment Group  
www.sfeg.co.uk





## PanBlast™ Fina II BSP Abrasive Control Valve



Surface Finishing  
Equipment Group

### **PanBlast™ Fina II BSP Abrasive Control Valve**

The PanBlast™ Fina II BSP Abrasive Control Valve is the latest generation in the Fina Valve Series. Developed from the original Fina Valve, the Series II Fina BSP Valve has several new features which make it one of the most efficient and effective abrasive valves available today.

The pipe nipple mounting system has been upgraded to eliminate locating the mounting holes in the nipple itself. This greatly reduces the risk of premature internal wear occurring at the point where the mounting bolts attach to the nipple.

A large drain plug has also been added to provide much easier clearing of blockages within the valve itself.

Servicing and maintenance is also simplified, as the entire control knob and plunger assembly can be removed from the valve body without the need to remove the valve from the blast pot. This allows both the plunger, urethane sleeve and the plunger seals to be changed quickly and easily.

As an added feature, all the internal wearing parts are fully interchangeable with the Series I Fina Valve, overcoming the need to hold differing parts in stock.

The Fina II Abrasive Control Valve is available in both BSP and NPT configurations.



Distributed by: Hogg Blasting & Finishing Equipment Ltd. Tel: 0191 415 3030 - Abraclean Ltd. Tel: 0161 480 8087 - Part of the Surface Finishing Equipment Group - www.sfeg.co.uk

## PanBlast™ Fina II BSP Valve Assemblies -

Stock Code	Description
BAC-VA-0277-00	Fina II BSP Valve - 1 1/4" M x 1 1/4" M BSP Nipple
BAC-VA-0278-00	Fina II BSP Valve - 1 1/2" M x 1 1/2" M BSP Nipple
BAC-VA-0279-00	Fina II BSP Valve - 1 1/4" M x 1 1/2" M BSP Nipple
BAC-VA-0280-00	Fina II BSP Valve - 1" F x 1 1/2" M BSP Nipple

## PanBlast™ Fina II BSP Valve Parts List -

Item	Stock Code	Description	Qty
1	YAC-VA-PB-0048	Spring Pin - Dia 5mm	1
2	BAC-VA-PB-0047	Control Knob	1
3	YAC-FN-PB-0225	Machine Screw - 5/16" UNC	2
4	YAC-FN-PB-0022	Flat Washer - 8mm	2
5	BAC-VA-0290-00	Fina II Valve Top Body	1
6	YAC-BS-0066-00	O-Ring 38.7mm x 3.55mm	2
7	BAC-VA-PB-0050	Fina Valve Plunger	1
8	YAC-VA-PB-0052	Fina Valve Plunger Seal	1
9	YAC-BS-PB-0032	O-Ring 28mm x 2mm	1
10	YAC-FN-0308-00	Split Pin - 3mm x 12mm	3
11	BAC-VA-0288-00	Fina II Valve Body	1
12	YAC-PF-PB-0231	Plug - 1" BSP	1
13	YAC-VA-PB-0053	Fina Valve Urethane Sleeve	1
14	YAC-VA-0313-00	Polyurethane Gasket	1
15	YAC-VA-0293-00	Half Ring Clamp	1
16	YAC-FN-PB-0118	Spring Washer 1/4"	2
17	YAC-FN-PB-0266	Socket Head Machine Screw	2

## PanBlast™ Fina II BSP Valve Pipe Nipples -

Item	Stock Code	Description	Qty
18	BAC-VA-0294-00	Fina II BSP Valve Pipe Nipple - 1 1/4" M x 1 1/4" M BSP	1
19	BAC-VA-0295-00	Fina II BSP Valve Pipe Nipple - 1 1/2" M x 1 1/2" M BSP	1
20	BAC-VA-0296-00	Fina II BSP Valve Pipe Nipple - 1 1/4" M x 1 1/2" M BSP	1
21	BAC-VA-0297-00	Fina II BSP Valve Pipe Nipple - 1" F x 1 1/2" M BSP	1

## PanBlast™ Fina II BSP Valve Service Kits -

Stock Code	Description
BAC-VA-0285-00	Fina II BSP Valve Service Kit - Includes items 1, 6, 7, 8, 9, 10, 13, 14, 16 & 17

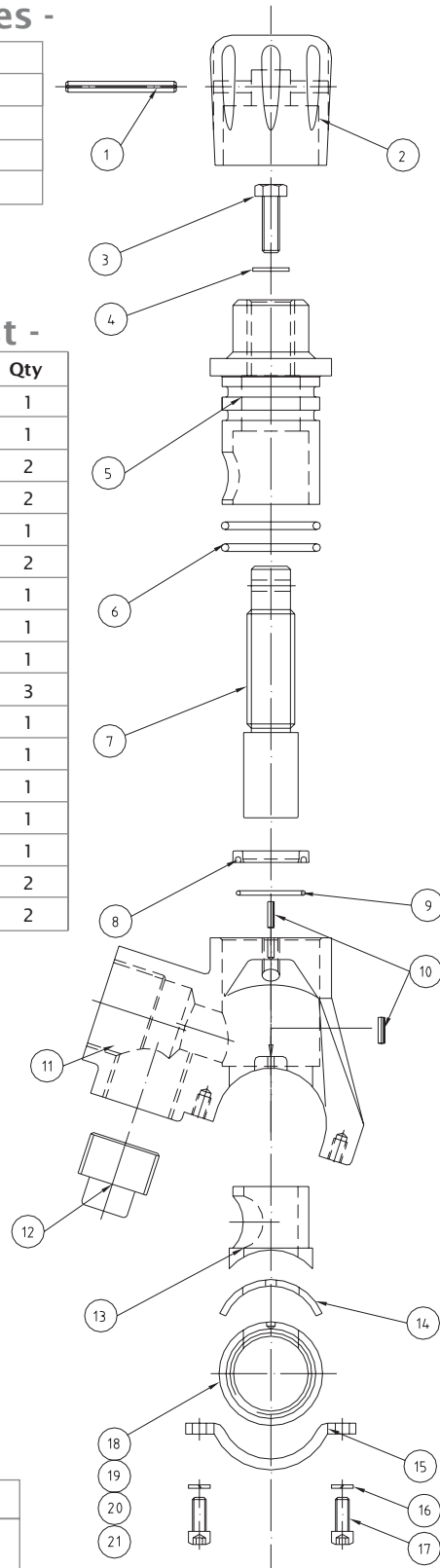

Blast Pots & Cabinets - Remote Control Valves - Abrasive Control Valves - Blast Nozzles - Nozzle Holders & Couplings - Helmets & Breathing Air Filters - Blast Suits



Surface Finishing  
Equipment Group



Distributed by:  
Hogg Blasting & Finishing Equipment Ltd  
Tel: 0191 415 3030

Abraclean Ltd  
Tel: 0161 480 8087

Part of the Surface Finishing Equipment Group  
www.sfeg.co.uk



## PanBlast™ Fina BSP Abrasive Control Valve



Surface Finishing  
Equipment Group

### **PanBlast™ Fina BSP Abrasive Control Valve**

The low profile PanBlast™ Fina BSP Valve offers one of the highest degrees of abrasive metering adjustment. This permits precise, constant abrasive flow to the blast nozzle, resulting in significant cost savings due to virtually no abrasive wastage.

The PanBlast™ Fina BSP Valve may be used with all abrasive types, from soft plastics through to aggressive metallics.

The simple design of the PanBlast™ Fina BSP Valve permits easy dismantling to remove obstructions or for maintenance.

A hardened steel plunger and orifice assembly meters abrasive flow to the nozzle. Abrasive flow adjustment is via a metering knob that adjusts the depth of the plunger into the orifice.



### **PanBlast™ Fina BSP Valve Design Features:**

- \* Hardened steel plunger for long operating life.
- \* Urethane plunger sleeve for smooth operation and precise abrasive metering.
- \* Easily dismantled for servicing and maintenance.
- \* Available with various size pipe connecting nipples.
- \* Complete range of replacement parts available.

All data and information is subject to change without notice. Brochure reference # 04-001 - Rev 01

Distributed by: Hogg Blasting & Finishing Equipment Ltd. Tel: 0191 415 3030 - Abraclean Ltd. Tel: 0161 480 8087 - Part of the Surface Finishing Equipment Group - www.sfeg.co.uk

## PanBlast™ Fina BSP Valve Assemblies -

Stock Code	Description	Weight
BAC-VA-PB-0060	Fina Valve - 1 1/4"M x 1 1/4" M	2.10kg (4.63lbs)
BAC-VA-PB-0061	Fina Valve - 1 1/2"M x 1 1/2"M	
BAC-VA-PB-0062	Fina Valve - 1 1/4"M x 1 1/2"M	
BAC-VA-PB-0063	Fina Valve - 1" F x 1 1/2"M	

## PanBlast™ Fina BSP Valve Parts List -

Item	Stock Code	Description	Qty
1	BAC-VA-PB-0047	Control Knob	1
2	YAC-VA-PB-0048	Spring Pin	1
3	YAC-FN-PB-0183	Bolt 5/16" UNC x 3 1/4" LG (ZP)	2
4	YAC-FN-PB-0022	M8 Flat Washer	2
5	BAC-VA-PB-0049	Top Body	1
6	BAC-VA-PB-0050	Plunger	1
7	BAC-VA-PB-0051	Valve Body	1
8	YAC-VA-PB-0052	Plunger Seal	1
9	YAC-VA-PB-0053	Urethane Sleeve	1
10	YAC-VA-PB-0054	Gasket	1
11	YAC-BS-PB-0032	O-Ring ID 28mm x Dia 2mm	1
12	YAC-BS-PB-0054	O-Ring ID 14.5mm x Dia 2.65mm	2

## PanBlast™ Fina BSP Valve Pipe Nipples -

Item	Stock Code	Description	Qty
13	BAC-VA-PB-0055	Pipe Nipple - 1 1/4" Male x 1 1/4" Male	1
14	BAC-VA-PB-0056	Pipe Nipple - 1 1/2" Male x 1 1/2" Male	1
15	BAC-VA-PB-0057	Pipe Nipple - 1 1/4" Male x 1 1/2" Male	1
16	BAC-VA-PB-0058	Pipe Nipple - 1" Female x 1 1/2" Male	1

## PanBlast™ Fina BSP Valve Service Kits -

Stock Code	Description
BAC-VA-PB-0016	Fina BSP Valve Service Kit - Includes items 2, 3, 4, 8, 9, 10 & 11
BAC-VA-PB-0122	Fina BSP Valve Urethane Sleeve Kit - Includes item 9 (3 off)

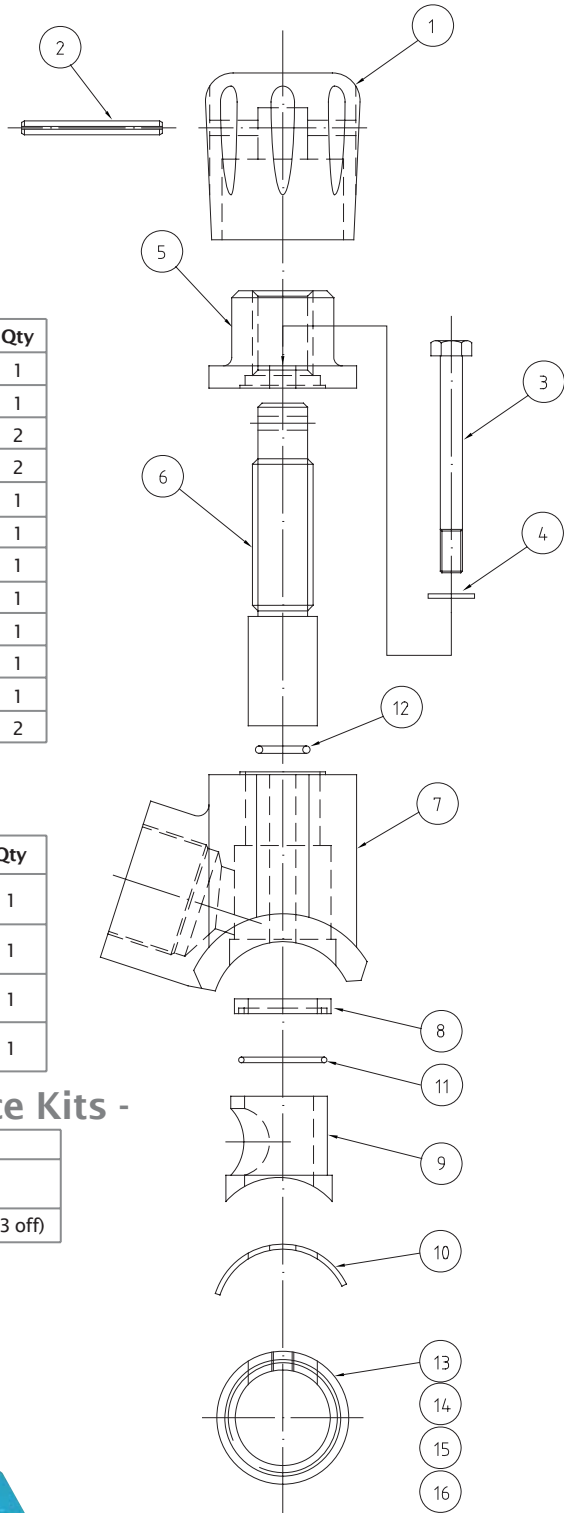

Blast Pots & Cabinets - Remote Control Valves - Abrasive Control Valves - Blast Nozzles - Nozzle Holders & Couplings - Helmets & Breathing Air Filters - Blast Suits



Surface Finishing  
Equipment Group



PanBlast™  
www.panblast.com

Distributed by:  
Hogg Blasting & Finishing Equipment Ltd  
Tel: 0191 415 3030

Abraclean Ltd  
Tel: 0161 480 8087

Part of the Surface Finishing Equipment Group  
www.sfeg.co.uk



## PanBlast™ Plana II BSP Abrasive Control Valve



Surface Finishing  
Equipment Group

### **PanBlast™ Plana II BSP Abrasive Control Valve**

The PanBlast™ Plana II BSP Abrasive Control Valve has evolved from the original Plana Valve, to become a simple in design, yet sophisticated in operation abrasive valve.

With a housing constructed from robust SG iron, and a metering plate constructed from stainless steel, the PanBlast™ Plana II BSP Valve takes this style of abrasive control valve to the next level of operation.

A set of nylon wiper seals provide sealing on each side of the metering plate, which prevents abrasive from entering the valve housing. This prevents jamming of the valve metering plate, which is a common problem with other types of flat type abrasive control valves.

A large clean out/inspection port, along with a drain port, are provided for greatly improved servicing and maintenance. Also featured is a pressurization port on the top housing, which allows a compressed air supply to be connected to assist in flushing out any blockages through the drain port.

Improved sealing of the metering plate stem using a combination of lip seals and O-Rings, is also a feature of the PanBlast™ Plana II BSP Abrasive Control Valve.

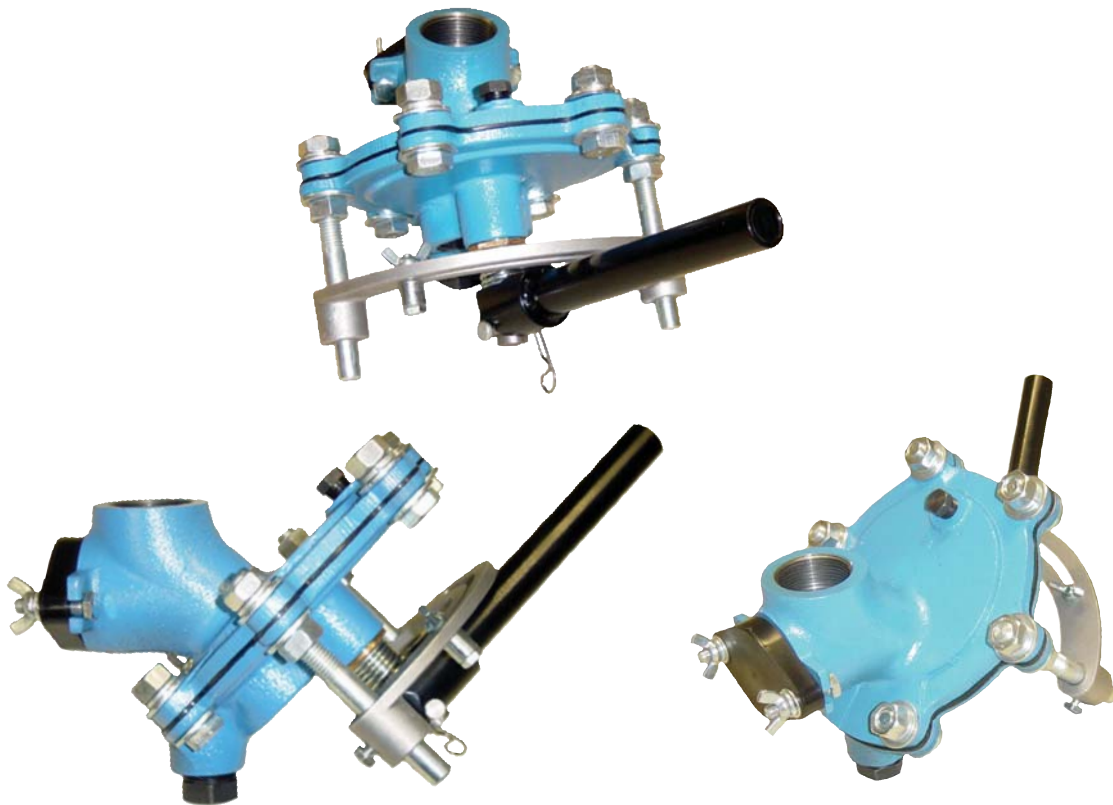

All data and information is subject to change without notice. Brochure reference # 04-009

Distributed by: Hogg Blasting & Finishing Equipment Ltd. Tel: 0191 415 3030 - Abraclean Ltd. Tel: 0161 480 8087 - Part of the Surface Finishing Equipment Group - www.sfeg.co.uk

## PanBlast™ Plana II BSP Valve Assembly -

Stock Code	Description
BAC-VA-0318-00	Plana II BSP Valve Assembly

## PanBlast™ Plana II BSP Valve Parts List -

Item	Stock Code	Description	Qty
1	YAC-FN-PB-0108	Wing Nut - 8mm	2
2	YAC-FN-PB-0022	Flat Washer - 8mm	2
3	YAC-VA-0309-00	Inspection Plate	1
4	YAC-BS-PB-0033	O-Ring 37.5mm x 3.53mm	1
5	YAC-FN-PB-0165	Hex Head Bolt - M8 x 40mm	2
6	BAC-VA-0320-00	Plana II Valve Upper Body	1
7	YAC-VA-0329-00	Seal Spring	1
8	YAC-BS-0068-00	Metering Plate Wiper Seal	2
9	YAC-VA-0322-00	Metering Plate	1
10	YAC-VA-0323-00	Rubber Gasket	1
11	BAC-VA-0324-00	Plana II Valve Lower Body	1
12	YAC-PF-PB-0083	Hex Plug - 3/4"	1
13	YAC-FN-PB-0035	Nut - M12	8
14	YAC-VA-PB-0084	Stud	2
15	YAC-FN-PB-0166	Machine Head Screw - M6 x 10mm	2
16	YAC-VA-PB-0083	Gauge Unit	1
17	YAC-BS-PB-0025	O-Ring 5/8" x 1/8"	3
18	YAC-BS-0073-00	O-Ring 17mm x 1.8mm	1
19	YAC-VA-0330-00	Shaft U Seal	1
20	YAC-VA-0332-00	Packing Gland	1
21	YAC-VA-0331-00	Bush	1
22	YAC-VA-PB-0077	Spring	1
23	YAC-FN-0332-00	R-Split Pin - 20mm	1
24	YAC-VA-0304-00	Handle Pin	1
25	YAC-VA-0305-00	Handle	1
26	YAC-FN-PB-0132	Hex Head Machine Screw - M6 x 25mm	1
27	YAC-VA-PB-0039	Gauge Unit Spacer	1
28	YAC-FN-PB-0007	Flat Washer - 6mm	1
29	YAC-FN-PB-0110	Wing Nut - M6	1
30	YAC-FN-PB-0064	Hex Head Bolt - M12 x 35mm	4
31	YAC-PF-PB-0088	Hex Plug - 1/4"	1
32	YAC-FN-PB-0085	Flat Washer - 12mm	12

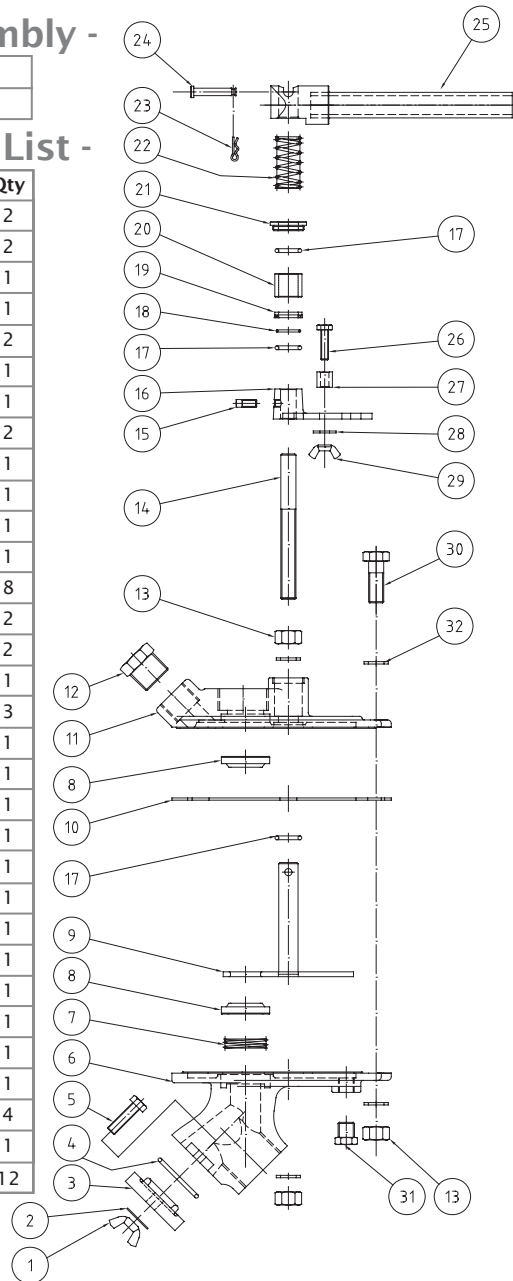

## PanBlast™ Plana II BSP Valve Service Kits -

Stock Code	Description
BAC-VA-0031-02	Plana II BSP Valve Service Kit - Includes items 9, 10, 17, 18, 19, 20, 21 & 22
BAC-VA-0328-00	Plana II BSP Valve Wiper Seal Kit - Includes items 7 & 8

## PanBlast™ Plana II BSP Valve Optional Items -

Item	Stock Code	Description	Qty
33	BAC-VA-PB-0074	Plana Valve Nipple	1
34	BAC-VA-PB-0073	Plana Valve Y Piece	1

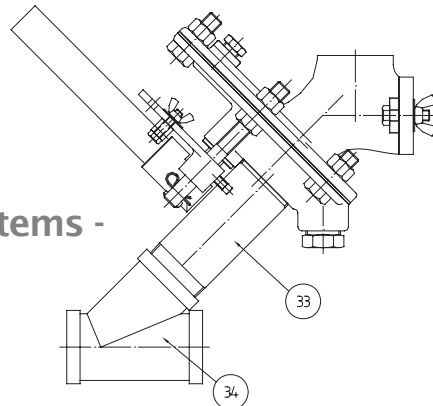

Blast Pots & Cabinets - Remote Control Valves - Abrasive Control Valves - Blast Nozzles - Nozzle Holders & Couplings - Helmets & Breathing Air Filters - Blast Suits



Surface Finishing  
Equipment Group



PanBlast™  
www.panblast.com

Distributed by:  
Hogg Blasting & Finishing Equipment Ltd  
Tel: 0191 415 3030

Abraclean Ltd  
Tel: 0161 480 8087

Part of the Surface Finishing Equipment Group  
www.sfeg.co.uk



# PanBlast™ Enviro Garnet BSP Abrasive Control Valve



Surface Finishing  
Equipment Group

## **PanBlast™ Enviro Garnet BSP Abrasive Control Valve**

The PanBlast™ Enviro Garnet BSP Abrasive Control Valve is a cost effective, manually operated, ball type abrasive feed control valve, specifically designed for use with garnet abrasive.

The Enviro Garnet BSP Abrasive Control Valve features a simple, robust design, constructed from grade 316 stainless steel, which provides long operating life, in even the most arduous conditions.

A urethane insert within the centre of the Enviro Garnet BSP Abrasive Control Valve is featured to provide accurate abrasive metering, and consistent flow.

The Enviro Garnet BSP Abrasive Control Valve features 32mm (1 1/4") threaded fitting for simple installation and the tie rod design provides for quick and easy dismantling of the valve assembly as and when required.



All data and information is subject to change without notice. Brochure reference # 04-006

Distributed by: Hogg Blasting & Finishing Equipment Ltd. Tel: 0191 415 3030 - Abraclean Ltd. Tel: 0161 480 8087 - Part of the Surface Finishing Equipment Group - www.sfeg.co.uk

## PanBlast™ Enviro Garnet BSP Valve Assembly -

Stock Code	Description	Weight
BAC-VA-PB-0112	Enviro BSP Valve Assembly	2.10kg (4.63lbs)

## PanBlast™ Enviro Garnet BSP Valve Parts List -

Item	Stock Code	Description	Qty
1	YAC-VA-PB-0111	Outer Body	1
2	YAC-VA-PB-0110	Inner Ball	1
3	YAC-VA-PB-0123	Polyurethane Insert	1

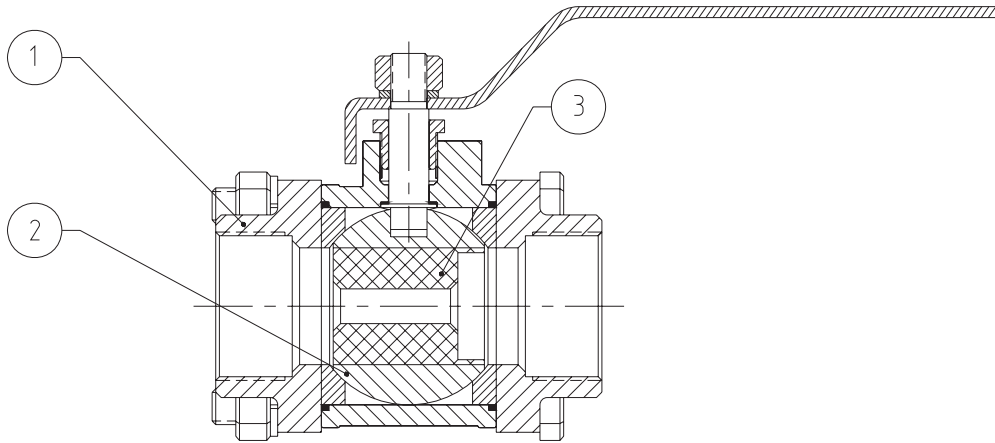

Blast Pots & Cabinets - Remote Control Valves - Abrasive Control Valves - Blast Nozzles - Nozzle Holders & Couplings - Helmets & Breathing Air Filters - Blast Suits



Surface Finishing  
Equipment Group



Distributed by:  
Hogg Blasting & Finishing Equipment Ltd  
Tel: 0191 415 3030

Abraclean Ltd  
Tel: 0161 480 8087

Part of the Surface Finishing Equipment Group  
www.sfeg.co.uk